

Eubanks

MODEL 6815-07 FLAT CABLE PREFEED



The 6815-07 Flat Cable Prefeed is designed exclusively for the Eubanks Model 4600 Cutter. It will handle Ribbon cable, Shrink Tubing, Nylon braids, Copper braids, Thin Flat Copper, or any other soft flat material that is rolled in a spool. The 6815-07 can support on its built-in arm a spool or reel weighing up to 60 Lbs (54kg).

SAFETY

The 6815-07 is designed as a stand-alone prefeed and can be used with any make of wire processing machine. When used with Eubanks 4600-03 Cutter, both the prefeed and the wire processor form an integrated system. This provides great safety as both prefeed and 4600 will shut down in the event of a wire jam or entanglement at the prefeed end due to poorly wound spools or reels.

PRACTICAL

Once the proper exit pulley height is set, there are no tools required to operate the 6880-03. Using the manual toggle switch to load and unload wire will help to safely speed up spool changes. Using the variable speed control knob, you can achieve maximum synchronization with the wire processor.

A 6880-05 will help increase accuracy in wire lengths and will help relieve any stresses to the materials.

SPECIFICATIONS

WIRE SIZE	Flat Ribbon Cables or Plastics: 3 in (76.2mm) Maximum Width Round Hose Tubing: .375 in (9.5mm) Maximum Diameter
REELS SIZE	Maximum Reel Outer Diameter 16 in (406mm) Maximum Reel Width 10 in (250mm) Minimum Reel Internal Diameter .750 in (19mm)
LOAD	60 lbs (27kg)
STANDARD TOOLING	One 11 in.(279.4mm) Spindle, One Spindle Collets, One Spindle Mounting Brackets, Two 11473 Feed Rollers, and a Detachable Power Cord
DIMENSIONS	24 in W x 18 in D x 40 in H. (610mm W x 457mm D x 1016mm H).
WEIGHT	Net: 80 lbs (36kg). Shipping: 110 lbs (50 Kg)

For best synchronization, adjust variable speed control knob until the lower spool moves up and stops below half way the travel length and holds in position until cycle is complete.

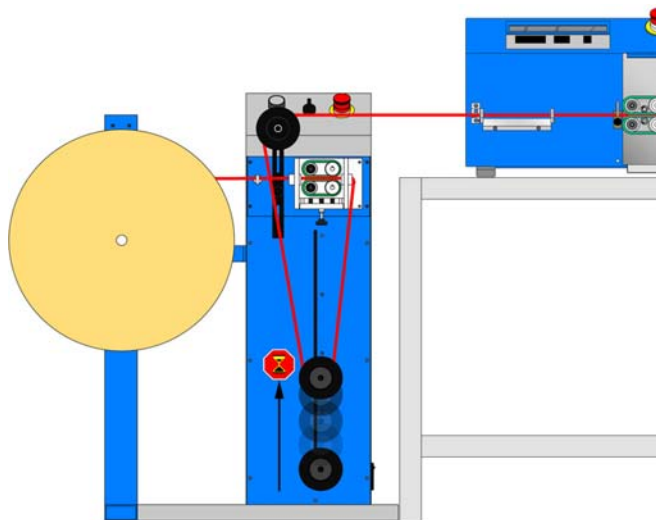

CAPACITY

60 LBS (27 kg) MAXIMUM LOAD

Flat Ribbon Cable or Flat Plastics

3 in (76.2mm) Maximum Width

Round Hose Tubing

.375 in (9.5mm) Maximum Outer Diameter

Maximum Reel/Spool Dimensions

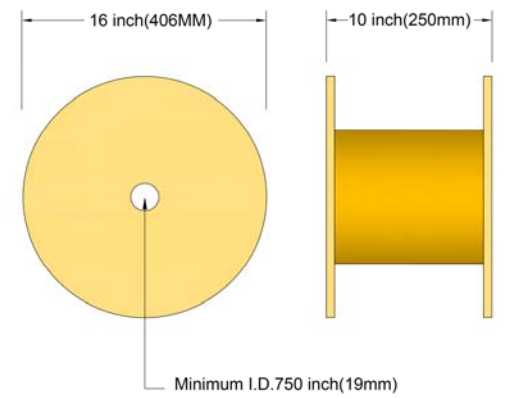

Hose Tubing



Ribbon Cable



Shrink Tubing



Nylon Braid



Copper Braid



Thin Flat Soft Copper



SPARE PARTS

#11473 Standard Neoprene Feed Roller



#7342 Feed Roller with Carbide Sprayed Surface



#1808 Spindle
11 in. (279.4mm) Long
#16555 Spindle
16 in. (406.4mm) Long

